

4

3

2

1

B

B

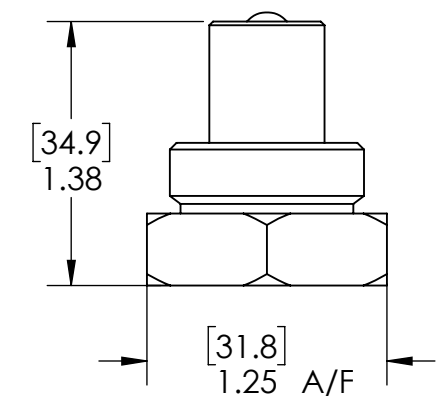
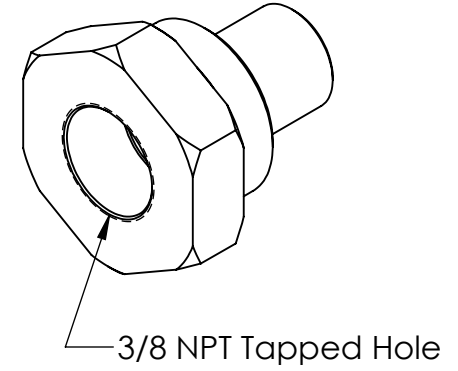
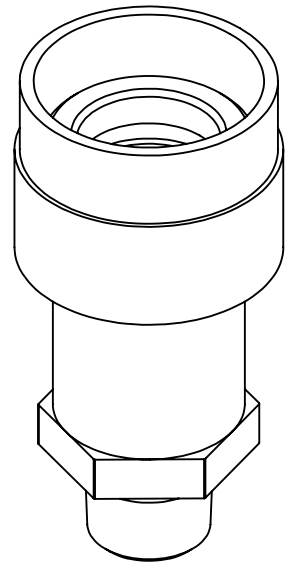
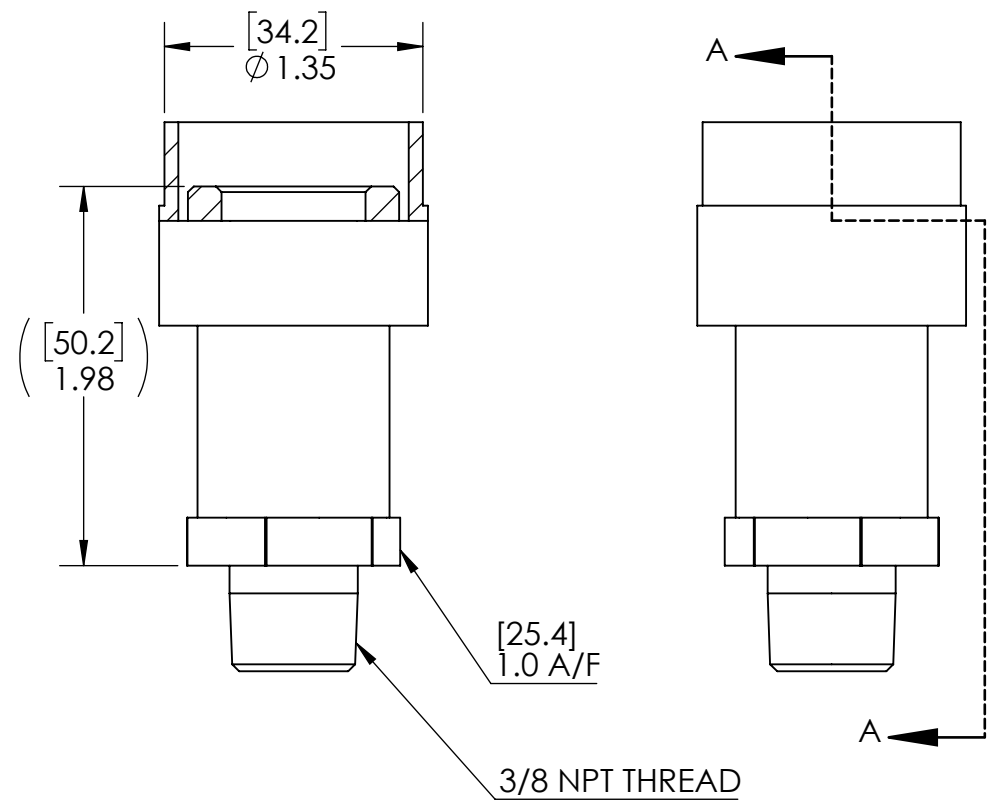

A

A

UNLESS OTHERWISE SPECIFIED: DIMENSIONS ARE IN INCHES.		NAME	DATE			
TOLERANCES: FRACTIONAL ±1/16 ANGLES ±1° TWO PLACES ±.050 (1.25mm) THREE PLACES ±.005 (.13mm) FOUR PLACES ±.001 (.02mm) FINISH 125 MAX C/B .020		JJJ	1/17/2018			
THIRD ANGLE PROJECTION		DRAWN	JJJ	TITLE: COUPLER SET		
		CHECKED				
		ENG APPR.	JJJ		1/18/2018	
		MFG APPR.				
MATERIAL		COMMENTS:		SIZE	DWG. NO.	REV
FINISH		PROJECT:		B	HFC-375	A
DO NOT SCALE DRAWING				SCALE: 1:1	WEIGHT:	SHEET 1 OF 1

A	C18-01-004	1/17/2018	JJJ	RELEASED	JJJ	1/18/2018
REV.	ECN.	DATE	DRAWNBY	DESCRIPTION	APPROVED	APPR. DATE
REVISIONS						

4

3

2

1