

4

3

2

1

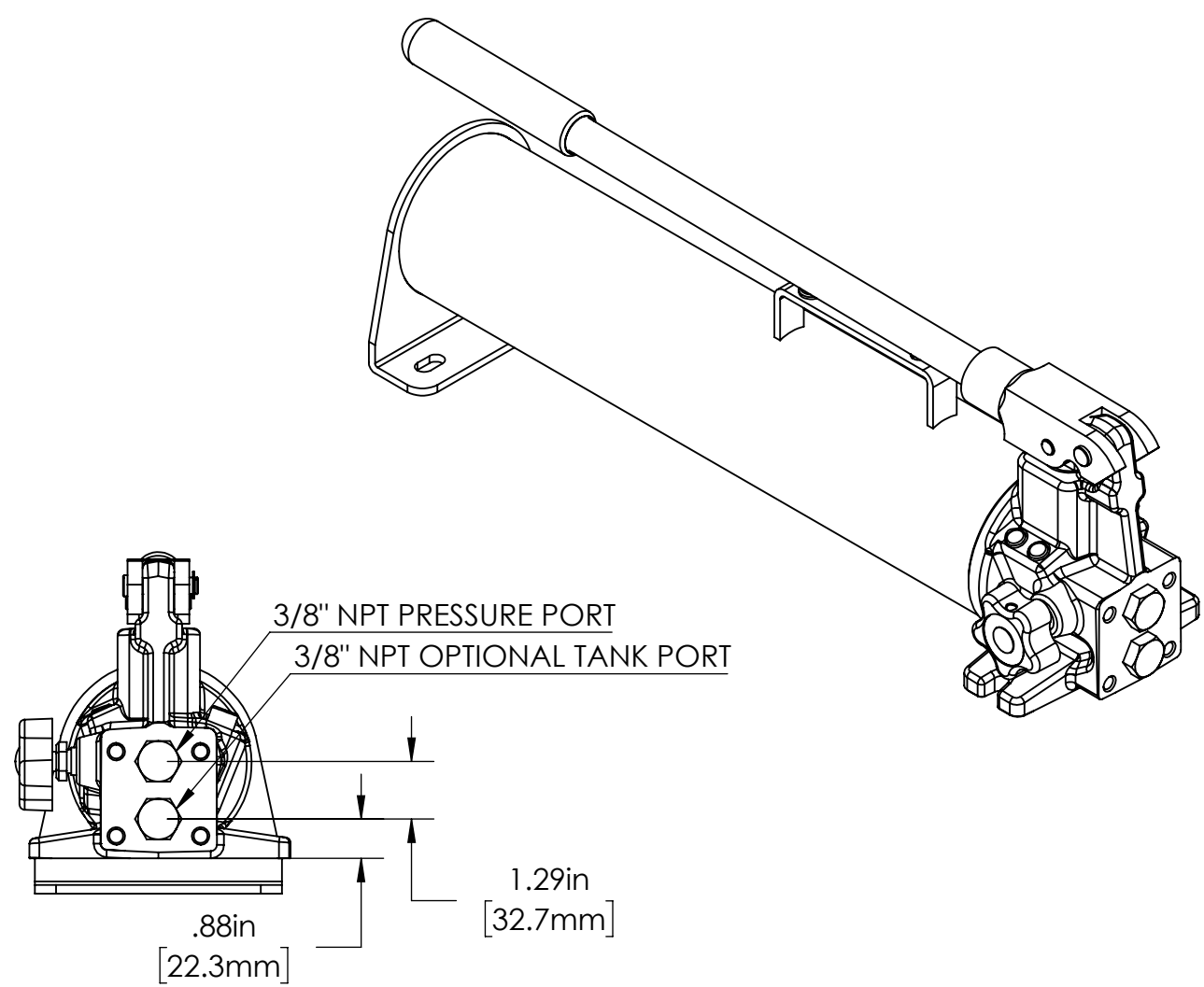
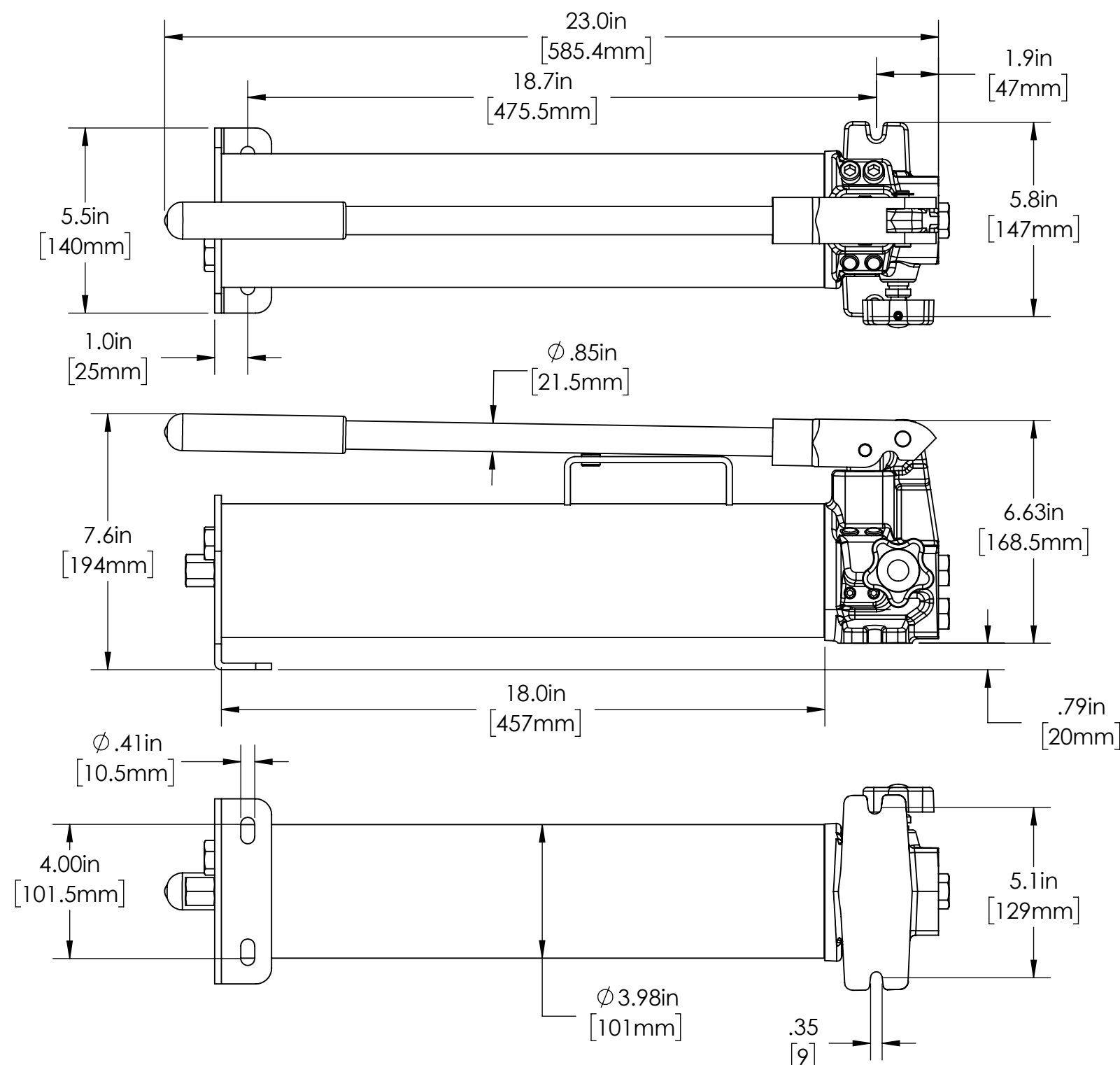

NOTES:

1. PRESSURE RATING
 1. 1ST STAGE: 10,000 PSI (700 BAR)
 2. 2ND STAGE: 300 PSI (21 BAR)
2. OIL VOLUME PER STROKE:
 1. 1ST STAGE: 0.79 CU.IN. (13 CC)
 2. 2ND STAGE: 0.17 CU.IN. (2.8 CC)
3. TOTAL OIL CAPACITY: 128 CU.IN (2,100 CC)
4. USABLE OIL CAPACITY: 110 CU.IN. (1,800 CC)
5. HANDLE EFFORT: 93 LBS. (42 KG)
6. PRODUCT WEIGHT WITH OIL: 28 LBS (12.7 KG)

UNLESS OTHERWISE SPECIFIED:
DIMENSIONS ARE IN INCHES.

TOLERANCES:
 FRACTIONAL ±1/16
 ANGLES ±1°
 ONE PLACES ±.050 (1.25mm)
 TWO PLACES ±.010 (.25mm)
 THREE PLACES ±.005 (.13mm)
 FINISH 125 MAX
 C/B .020

THIRD ANGLE PROJECTION

PROPRIETARY AND CONFIDENTIAL

THE INFORMATION CONTAINED IN THIS DRAWING IS THE SOLE PROPERTY OF PowerX International. ANY REPRODUCTION IN PART OR AS A WHOLE WITHOUT THE WRITTEN PERMISSION OF PowerX International IS PROHIBITED.

MATERIAL

FINISH

DO NOT SCALE DRAWING

	NAME	DATE
DRAWN	JJJ	10/15/18
CHECKED		
ENG APPR.	JJJ	10/22/18
MFG APPR.		
Q.A.		
COMMENTS:		



TITLE:
PUMP, HAND, TWO STAGE, INSTALLATION

SIZE	DWG. NO.	REV
B	P122 - Install	A
SCALE: 1:4	WEIGHT:	SHEET 1 OF 1

REV.	ECN.	DATE	DRAWNBY	DESCRIPTION	APPROVED	APPR. DATE
A	C18-10-129	10/22/2018	JJJ	RELEASE OF DRAWING	JJJ	10/22/18
REVISIONS						

4

3

2

1

B

B

A

A