

4

3

2

1

B

B

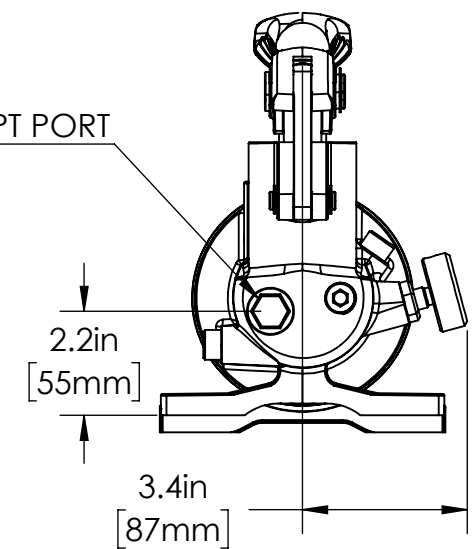
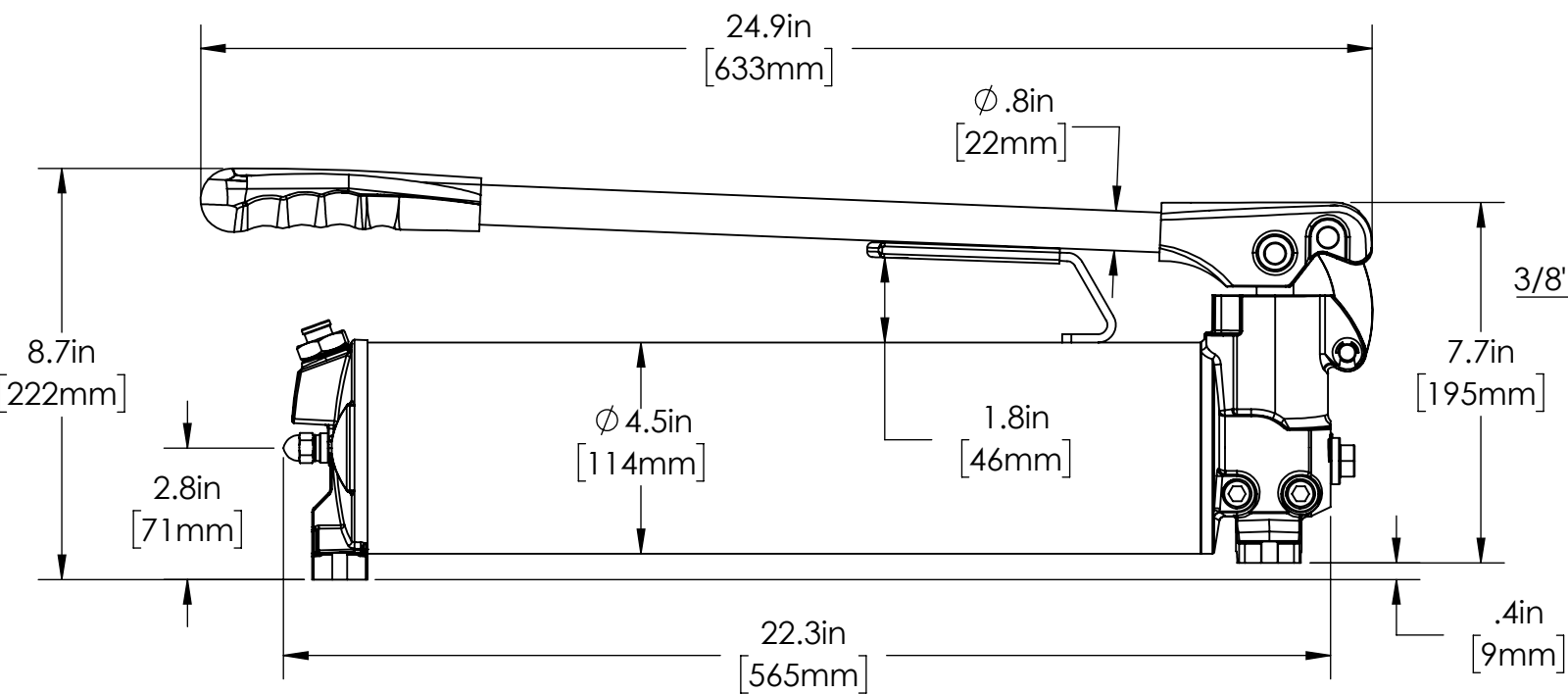
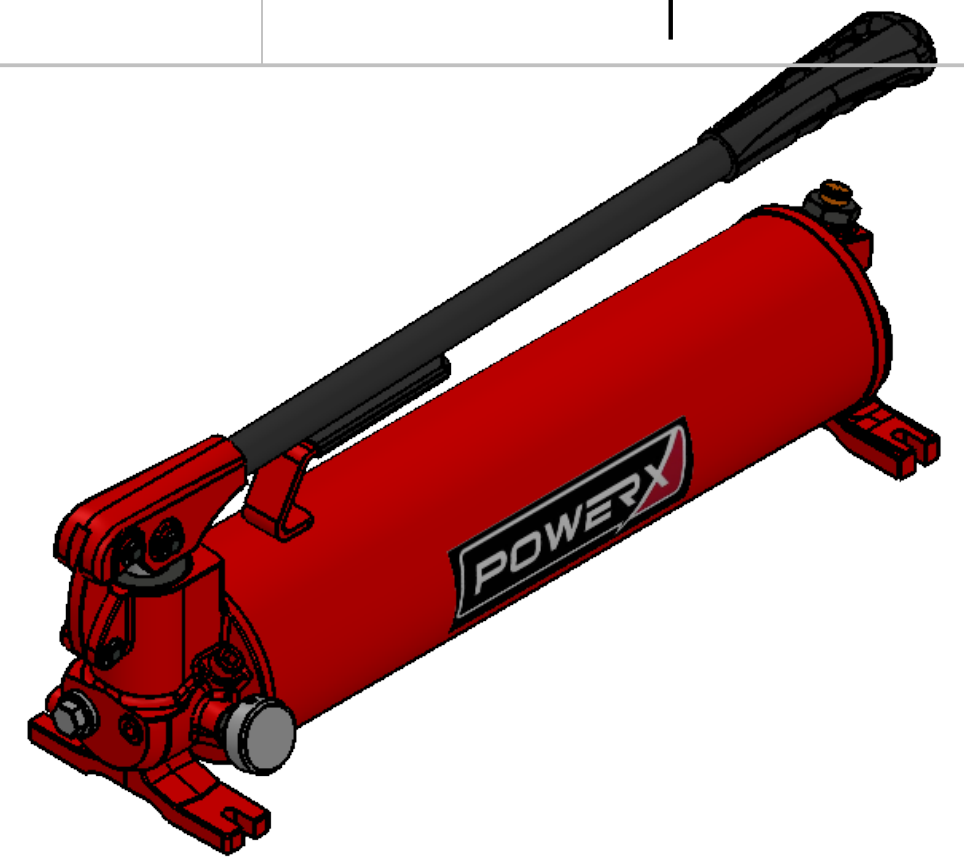
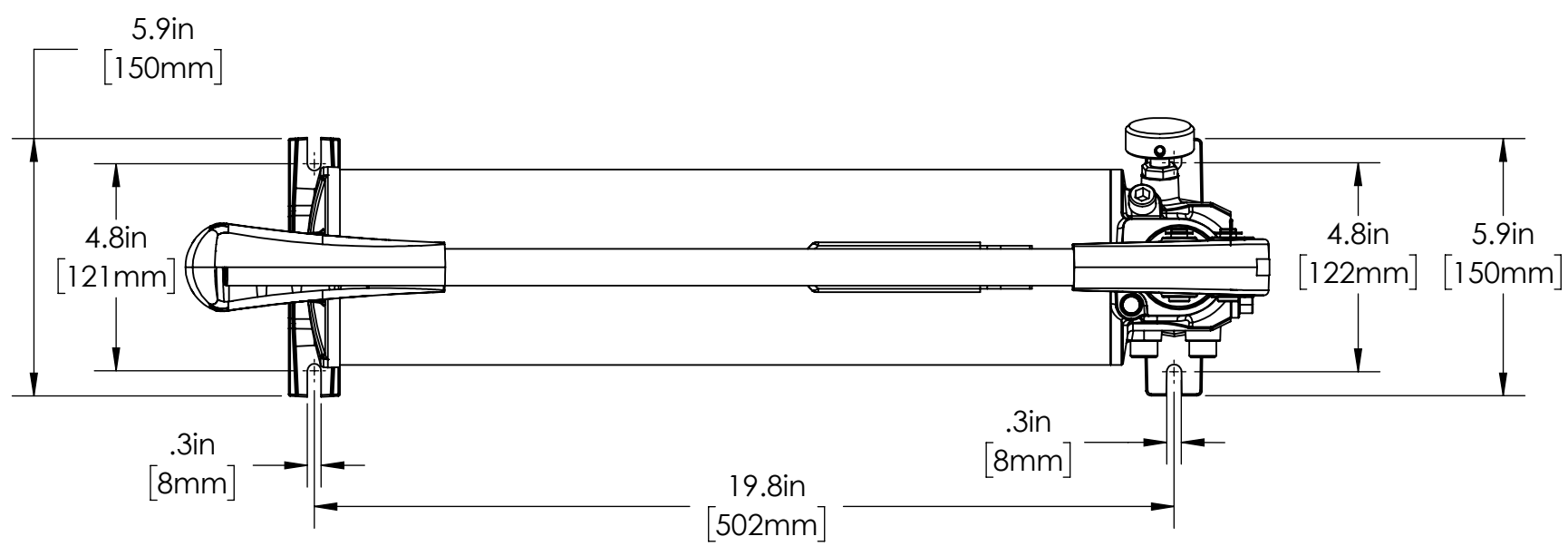

NOTES:

1. PRESSURE RATING:
 1. 1ST STAGE - 400 PSI (27.5 BAR)
 2. 2ND STAGE - 10,000 PSI (700 BAR)
2. OIL VOLUME PER STROKE
 1. 1ST STAGE - 2.4 CU.IN. (39.5 CC)
 2. 2ND STAGE - 0.17 CU.IN. (2.8 CC)
3. TOTAL OIL CAPACITY - 153 CU.IN. (2,500 CC)
4. USABLE OIL CAPACITY - 122 CU.IN. (2,000 CC)
5. HANDLE EFFORT - 82 LBS (37 KG)
6. WEIGHT - 26 LBS (12 KG)
7. COLOR - POWERX RED FOR BODY AND BLACK HANDLE AND HANDLE GRIP

A

A

UNLESS OTHERWISE SPECIFIED:
DIMENSIONS ARE IN INCHES.

TOLERANCES:
 FRACTIONAL ±1/16
 ANGLES ±1°
 ONE PLACES ±.050 (1.25mm)
 TWO PLACES ±.010 (.25mm)
 THREE PLACES ±.005 (.13mm)
 FINISH 125 MAX
 C/B .020

THIRD ANGLE PROJECTION

PROPRIETARY AND CONFIDENTIAL
 THE INFORMATION CONTAINED IN THIS DRAWING IS THE SOLE PROPERTY OF PowerX International. ANY REPRODUCTION IN PART OR AS A WHOLE WITHOUT THE WRITTEN PERMISSION OF PowerX International IS PROHIBITED.

	NAME	DATE
DRAWN	JJJ	1/9/18
CHECKED		
ENG APPR.	JJJ	1/9/18
MFG APPR.		
Q.A.		
COMMENTS:		



TITLE:		
SIZE	DWG. NO.	REV
B	P122HF Install	B
SCALE: 1:4	WEIGHT:	SHEET 1 OF 1

REV.	ECN.	DATE	DRAWNBY	DESCRIPTION	APPROVED	APPR. DATE
B	C18-12-149	12/18/2018	JJJ	ASSOCIATED DRAWING WITH ACTUAL MODEL	JJJ	12/19/18
A	-	01/08/2018	JJJ	RELEASE OF DOCUMENT	JJJ	01/09/18
REVISIONS						

4

3

2

1