

4

3

2

1

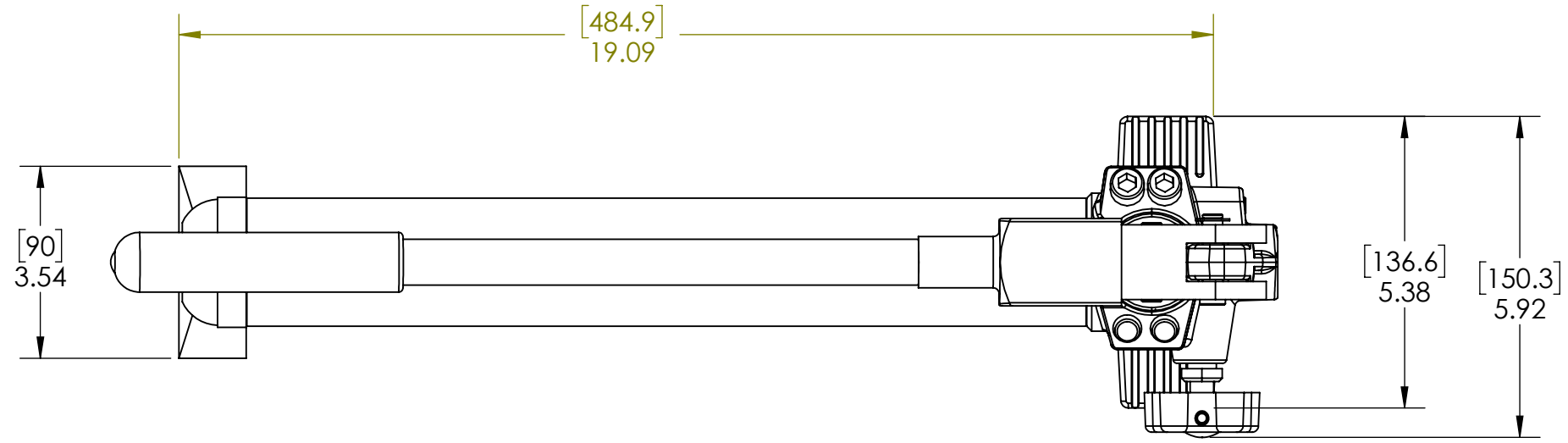

NOTES:

1. PRESSURE RATING
 1. 1ST STAGE: 10,000 PSI (700 BAR)
 2. 2ND STAGE: 200 PSI (15 BAR)
2. OIL VOLUME PER STROKE:
 1. 1ST STAGE: 0.79 CU.IN. (13 CC)
 2. 2ND STAGE: 0.17 CU.IN. (2.8 CC)
3. TOTAL OIL CAPACITY: 46.0 CU.IN (750 CC)
4. USABLE OIL CAPACITY: 37 CU.IN. (600 CC)
5. HANDLE EFFORT: 97 LBS. (44 KG)
6. PRODUCT WEIGHT WITH OIL: 17 LBS (7.7 KG)

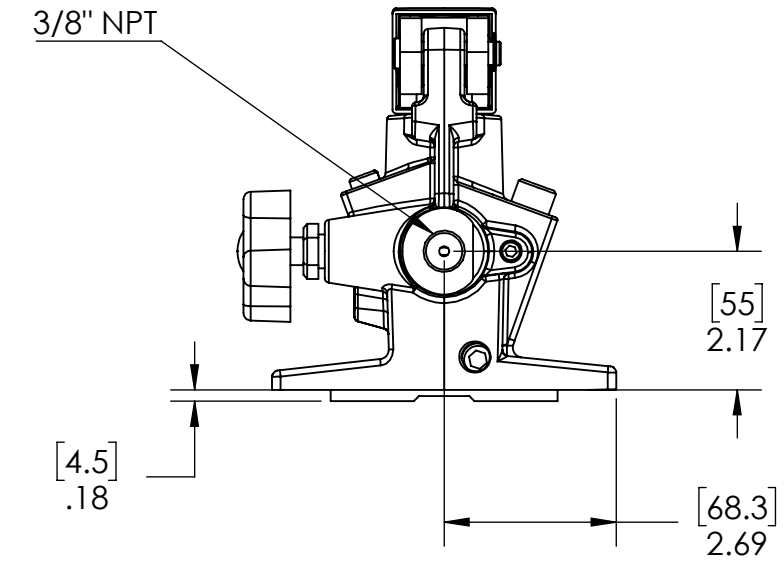
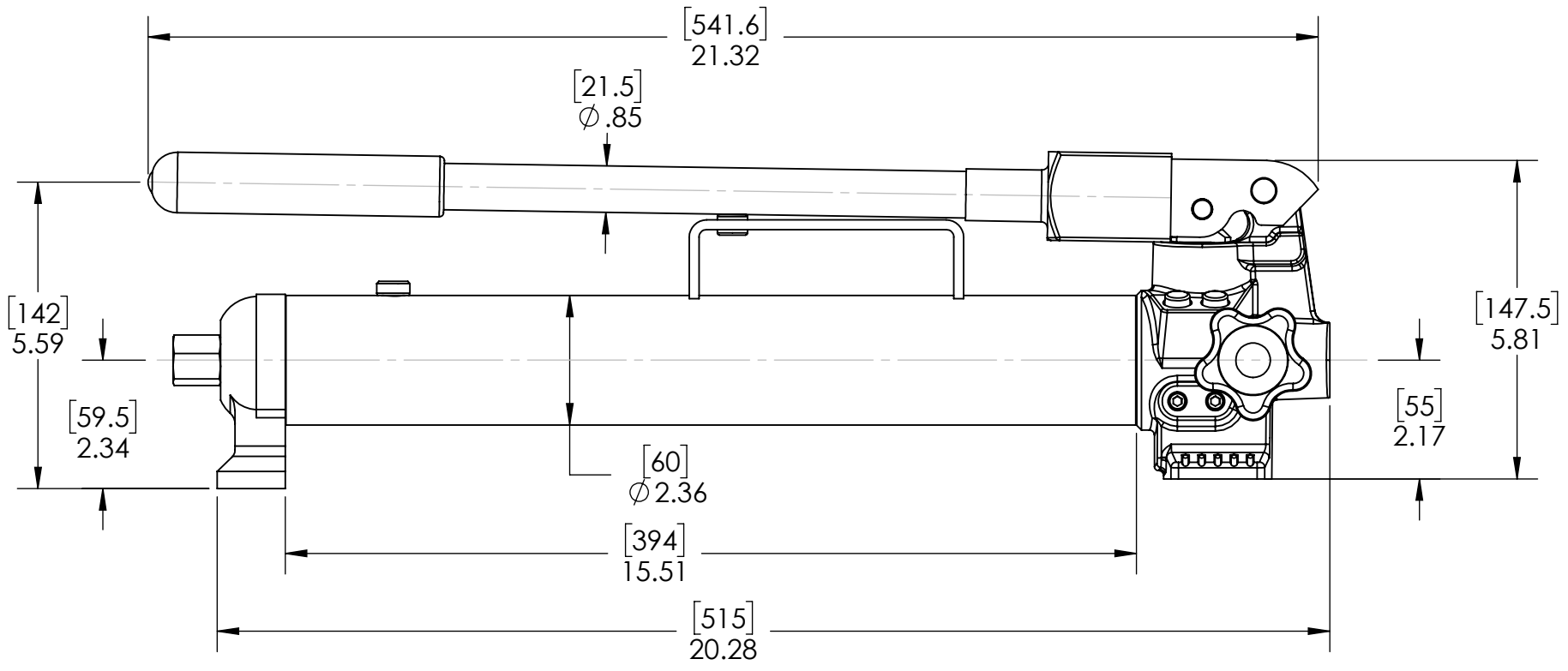

B

B

A

A

UNLESS OTHERWISE SPECIFIED:
 DIMENSIONS ARE IN INCHES.
 TOLERANCES:
 FRACTIONAL ±1/16
 ANGLES ±1°
 TWO PLACES ±.010 (.25mm)
 THREE PLACES ±.005 (.13mm)
 FOUR PLACES ±.001 (.02mm)
 FINISH 125 MAX
 C/B .020

THIRD ANGLE PROJECTION
PROPRIETARY AND CONFIDENTIAL
 THE INFORMATION CONTAINED IN THIS DRAWING IS THE SOLE PROPERTY OF PowerX International. ANY REPRODUCTION IN PART OR AS A WHOLE WITHOUT THE WRITTEN PERMISSION OF PowerX International IS PROHIBITED.

MATERIAL
 Material <not specified>
 FINISH
 DO NOT SCALE DRAWING

	NAME	DATE
DRAWN	JJJ	03/01/2018
CHECKED		
ENG APPR.	JJJ	03/02/2018
MFG APPR.		
Q.A.		
COMMENTS:		
PROJECT:		

POWERX		
TITLE: PUMP,HAND,2 STAGE		
SIZE B	DWG. NO. P37 - Install	REV B
SCALE: 1:3		SHEET 1 OF 1

REV.	ECN.	DATE	DRAWNBY	DESCRIPTION	APPROVED	APPR. DATE
B	C18-06-062	6/6/2018	JJJ	UPDATED FILE NAME	JJJ	6/6/18
A	C18-03-021	03/01/2018	JJJ	RELEASED	JJJ	03/02/2018
REVISIONS						

4

3

2

1