

4

3

2

1

NOTES:

- 1. PRESSURE RATING: 10,000 PSI (700 BAR)
- 2. OIL VOLUME PER STROKE: 0.20 CU.IN. (3.2 CC)
- 3. TOTAL OIL CAPACITY: 52 CU.IN (850 CC)
- 4. USABLE OIL CAPACITY: 43 CU.IN. (705 CC)
- 5. HANDLE EFFORT: 90 LBS. (41 KG)
- 6. PRODUCT WEIGHT WITH OIL: 17 LBS (7.7 KG)

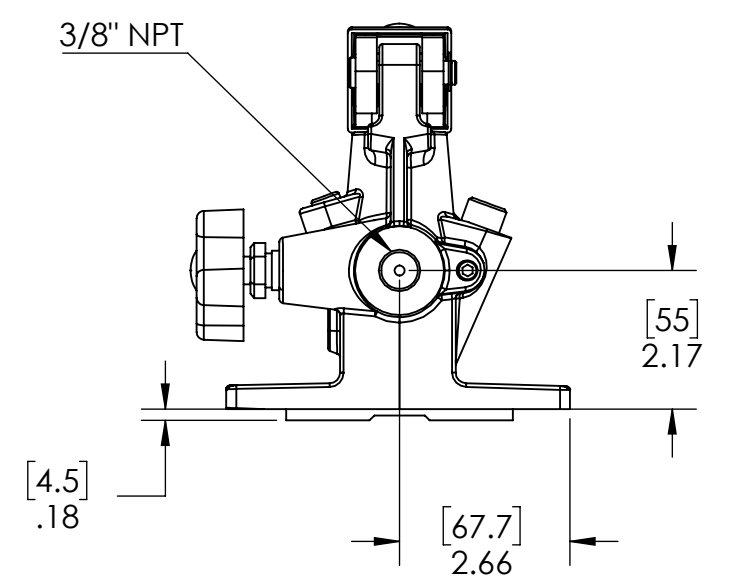
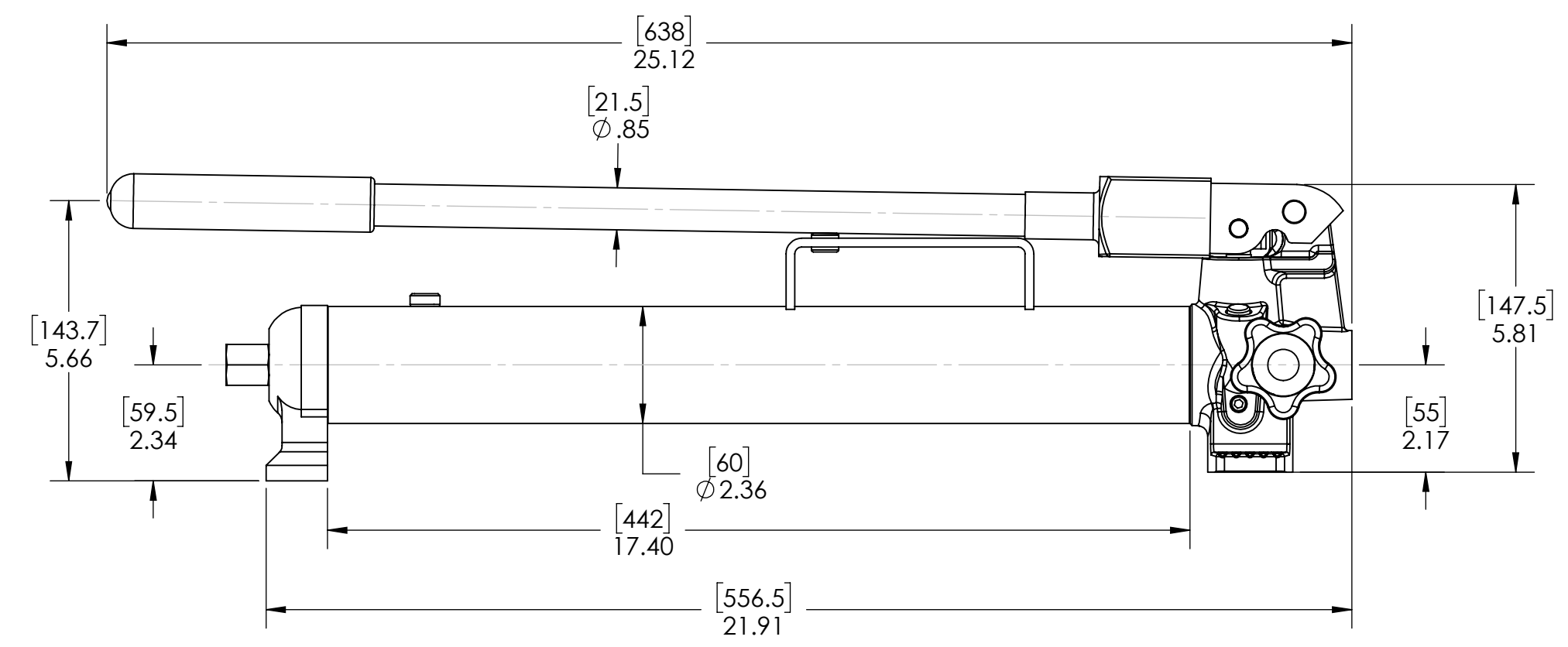
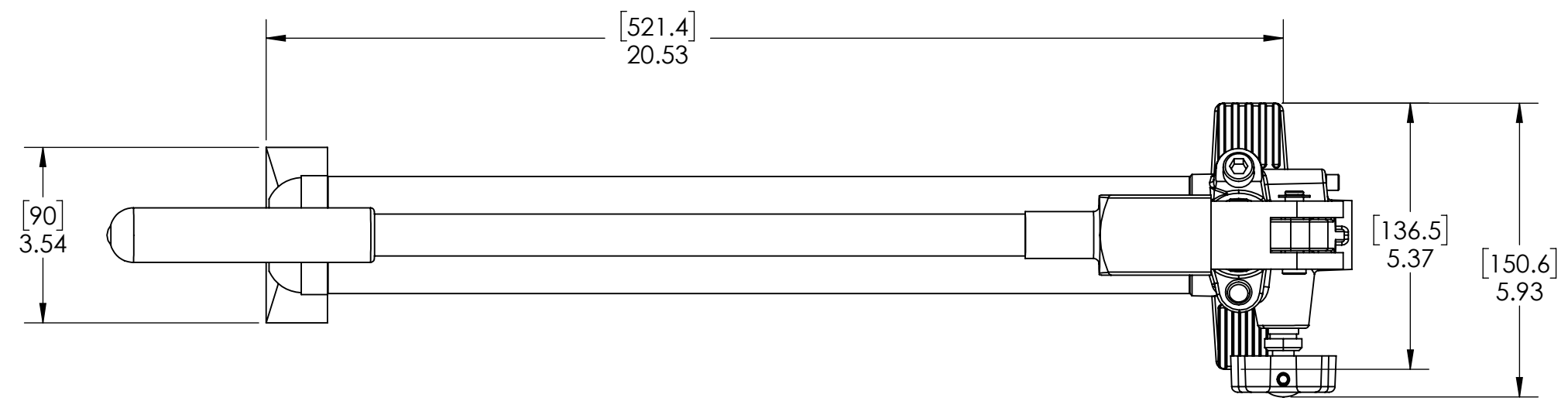

REV.	ECN.	DATE	DRAWNBY	DESCRIPTION	APPROVED	APPR. DATE
B	C18-06-062	6/6/2018	JJJ	UPDATED FILE NAME	JJJ	6/6/18
A	C-03-021	03/02/2018	JJJ	RELEASED	JJJ	03/02/2018
REVISIONS						

<p>UNLESS OTHERWISE SPECIFIED: DIMENSIONS ARE IN INCHES.</p> <p>TOLERANCES: FRACTIONAL ±1/16 ANGLES ±1° TWO PLACES ±.010 (.25mm) THREE PLACES ±.005 (.13mm) FOUR PLACES ±.001 (.02mm) FINISH 125 MAX C/B .020</p> <p>MATERIAL Material <not specified> FINISH</p> <p>DO NOT SCALE DRAWING</p>	<p>THIRD ANGLE PROJECTION</p>	<p>PROPRIETARY AND CONFIDENTIAL</p> <p>THE INFORMATION CONTAINED IN THIS DRAWING IS THE SOLE PROPERTY OF PowerX International. ANY REPRODUCTION IN PART OR AS A WHOLE WITHOUT THE WRITTEN PERMISSION OF PowerX International IS PROHIBITED.</p>	<table border="1"> <thead> <tr> <th>NAME</th> <th>DATE</th> </tr> </thead> <tbody> <tr> <td>JJJ</td> <td>03/01/2018</td> </tr> <tr> <td>JJJ</td> <td>03/02/2018</td> </tr> </tbody> </table>	NAME	DATE	JJJ	03/01/2018	JJJ	03/02/2018	
	NAME	DATE								
	JJJ	03/01/2018								
	JJJ	03/02/2018								
<p>TITLE: PUMP, HAND, SINGLE STAGE</p>			<p>SIZE B DWG. NO. P43 - Install REV B</p>							
<p>PROJECT:</p>			<p>SCALE: 1:3 SHEET 1 OF 1</p>							

4

3

2

1