

4

3

2

1

B

B

A

A

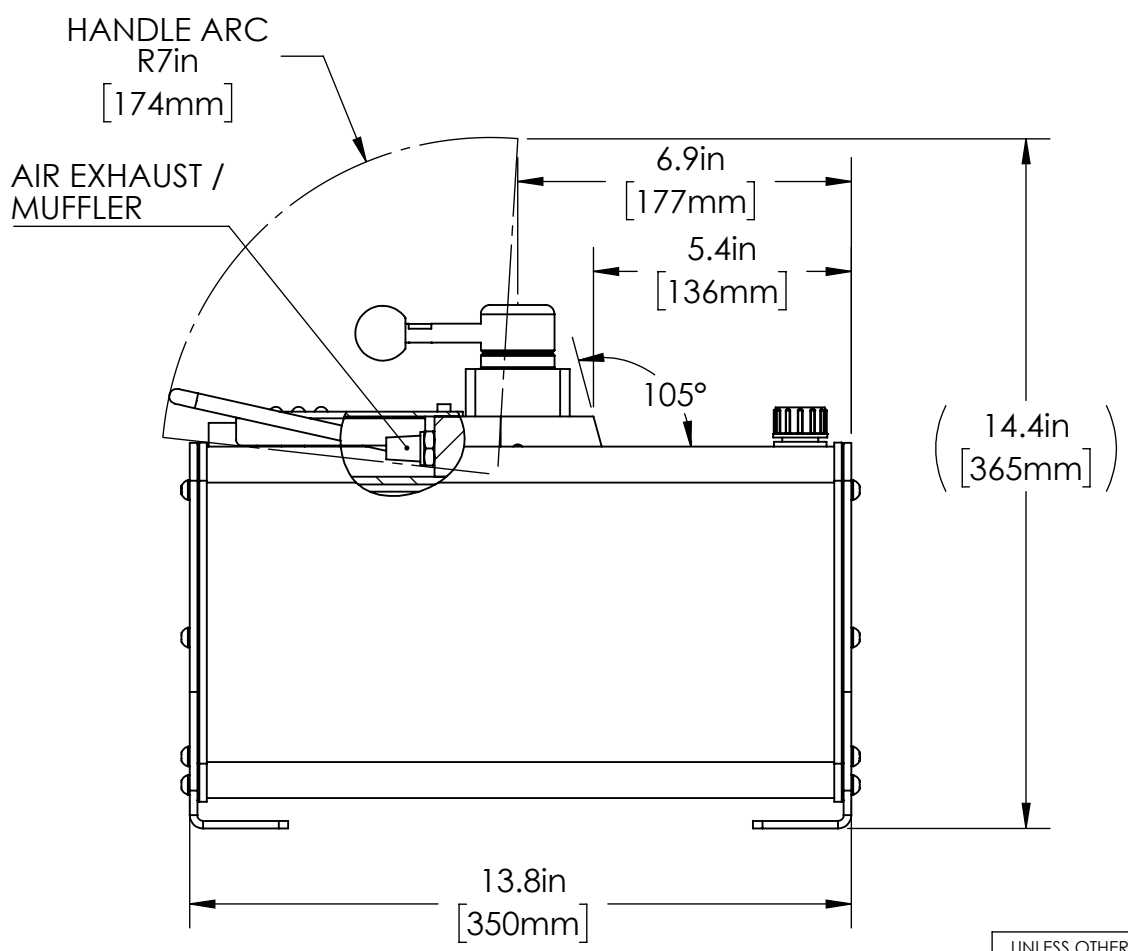
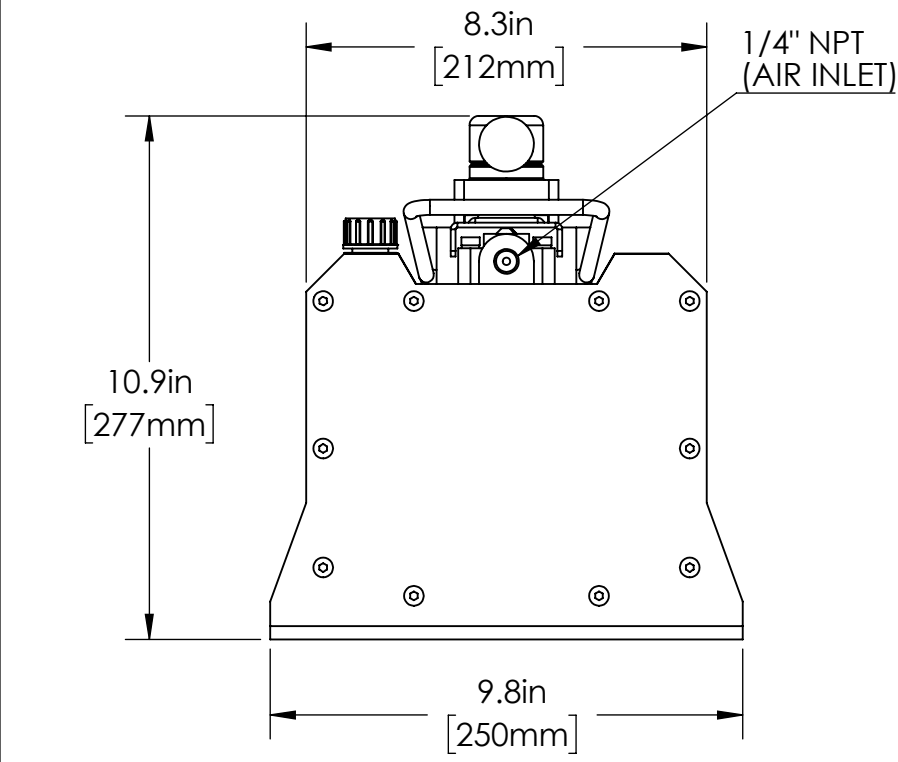
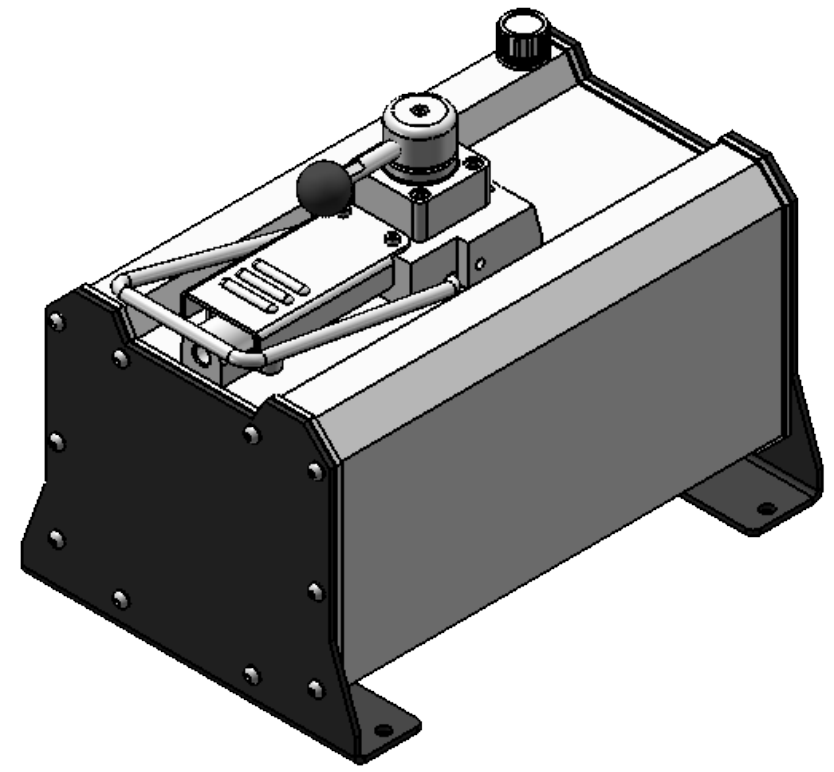
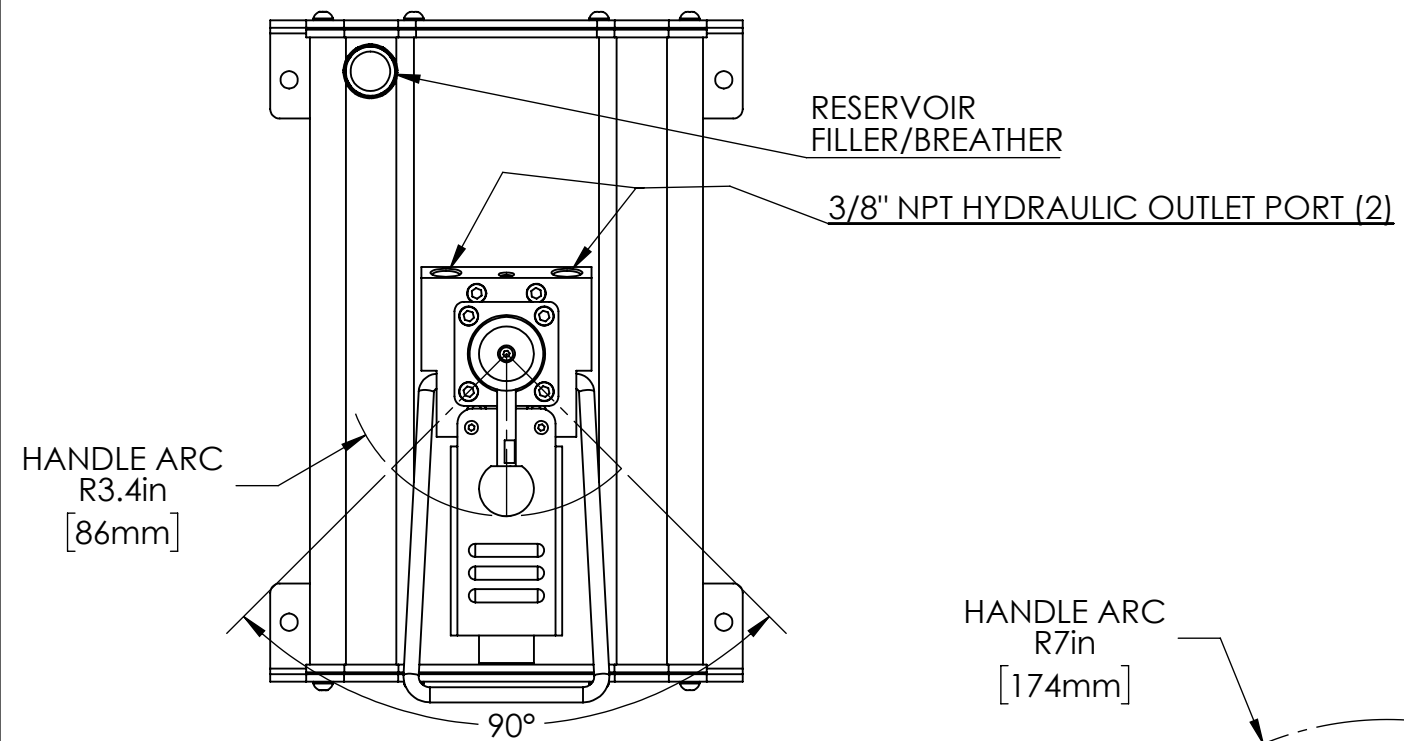

NOTES:

1. MAXIMUM PRESSURE RATING 10,000 PSI OTHER PRESSURES AVAILABLE UPON REQUEST.
2. INLET AIR PRESSURE: 40 TO 170 PSI
3. AIR EXHAUST MUFFLER INCLUDED.
4. RESERVOIR OIL CAPACITY, APPROX. 550 CU.IN.
5. USUABLE OIL VOLUME 460 CU.IN.
6. OIL FLOW:
 1. NO LOAD: 82 CU.IN./MIN
 2. 10,000 PSI: 13 CU.IN./MIN
7. RESERVOIR, EXTRUDED ALUMINUM ALLOY
8. VALVE, DOUBLE ACTING, 3P / 4W WITH DETENTS.
9. WEIGHT: APPROX. 44 LBS, INCLUDING OIL

UNLESS OTHERWISE SPECIFIED:
DIMENSIONS ARE IN INCHES.

TOLERANCES:
FRACTIONAL ±1/16
ANGLES ±1°
ONE PLACES ±.050 (.125mm)
TWO PLACES ±.010 (.25mm)
THREE PLACES ±.005 (.13mm)
FINISH 125 MAX
C/B .020

THIRD ANGLE PROJECTION

PROPRIETARY AND CONFIDENTIAL

THE INFORMATION CONTAINED IN THIS DRAWING IS THE SOLE PROPERTY OF PowerX International. ANY REPRODUCTION IN PART OR AS A WHOLE WITHOUT THE WRITTEN PERMISSION OF PowerX International IS PROHIBITED.

	NAME	DATE
DRAWN	JJJ	03/29/18
CHECKED		
ENG APPR.		
MFG APPR.		
Q.A.		
COMMENTS:		

POWERX

TITLE:
INSTALLATION DRAWING

SIZE	DWG. NO.	REV
B	PA6-460D	A
SCALE: 1:4	WEIGHT:	SHEET 1 OF 1

REV.	ECN.	DATE	DRAWNBY	DESCRIPTION	APPROVED	APPR. DATE
REVISIONS						

4

3

2

1